

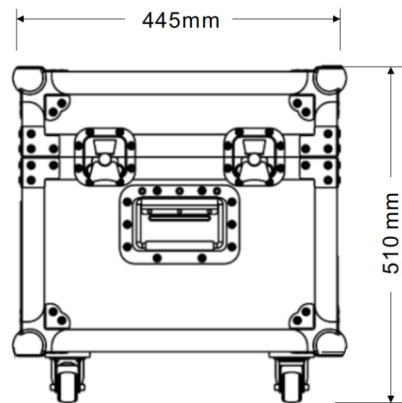

Stage Effect Fogger

TL-SL611

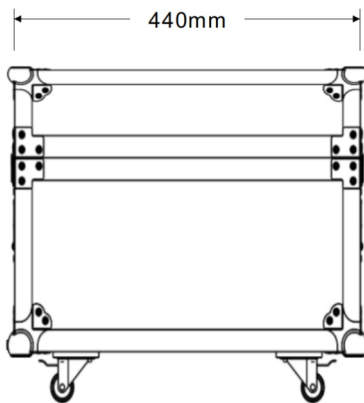

Feature:

- * Fog output: 3200cuft/min.
- * Preheating time: 0Min.

Specifications:

Model	TL-SL611
Input voltage	AC 220-240V 50Hz, 750W
Fuse	10 A/250 V
Working current	6.5A
Fog liquid drum	2L
Fog liquid consumption	24h/L
Control mode	DMX512 control, remote control 2 channels Channel 1: turn on and off the fog output Channel 2: adjust the wind power
Channel	
Protection class	IP20
Product size (L×W×H)	445×440×510mm (flight case)
Net weight	36.0kg