

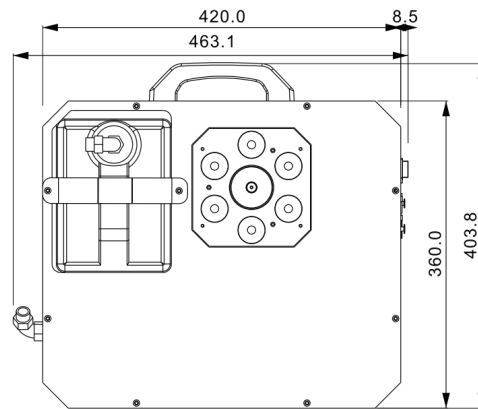

Stage Effect Fogger

TL-SL602

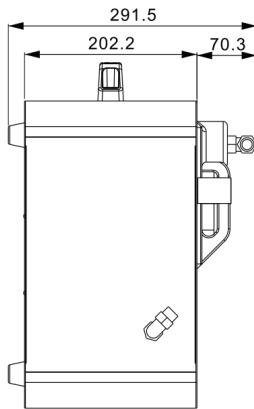

Feature:

- * Color mixing: RGBWAP stepless color mixing.
- * Maximum fog output: about 32,000 cubic feet per minute.
- * Maximum spray distance: about 4-6m.
- * Maximum fog liquid consumption: about 7 min/L.
- * Maximum continuous output time (100 output): about 30 seconds.
- * Output time with full load of consumables (100 output): about 25 minutes.

Specifications:

Model	TL-SL602
Input voltage	AC 220-240V 50Hz, 1500W
Fuse	10A/250V
Working current	6.5 A
LED color	RGBWAP, adjustable color
Power of a lamp bead	10 W
Number of lamp bead	6 pieces
Preheating time	About 4.0 minutes
Heater (heating aluminum/speed heater)	Heating aluminum
Fog liquid drum	4.0 L
Control mode	Support DMX512 and wireless control, the maximum wireless control distance can reach 50m
Channel	7/11CH
Protection class	IP20
Product size (L×W×H)	463×404×291.5mm
Package size (L×W×H)	515×460×350mm
Net weight	11.5kg