

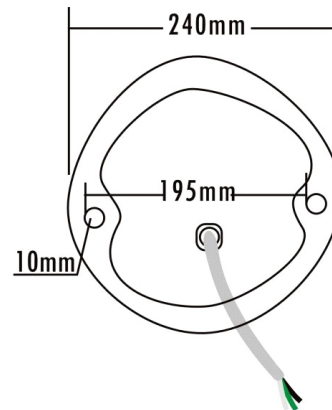

Garden Speaker

VA-500

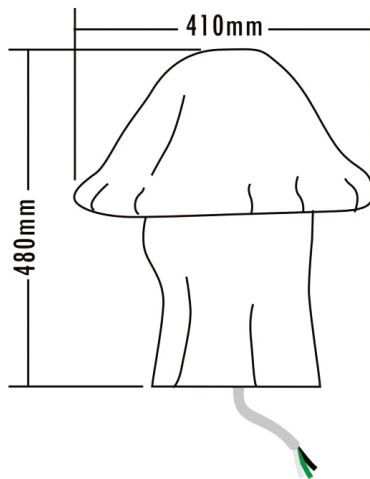

Material: Organic Resin

Note:

Due to the continuous product updating, the color and dimension of the products are subject to the actual product. The following specifications are for reference only.

Specifications:

Model	VA-500
Rated Power(100V)	15W, 30W
Frequency Response	120-15KHz
Sensitivity	95dB
Maximum sound pressure level	110dB
Speaker Unit	6.5"
IP Level	IP66
Installation Size(mm)	195mm
Weight	5.16kg
Product Size(mm)	410x480mm